

C2N-IRGW-1G

IR Gateway, Wall Mount

The C2N-IRGW-1G IR Gateway is a 1-way infrared receiver for Crestron IR wireless handheld remotes and touchpanels. It is also compatible with third-party IR remotes utilizing the RC5 command set.

The C2N-IRGW-1G is designed to fit in a 1-gang electrical box using a Decora® style faceplate (not included). Its entire visible face consists of a smoked plastic lens providing a neutral appearance suitable for use with any color scheme. The C2N-IRGW-1G is a Cresnet device compatible with any 2-Series control system.

SPECIFICATIONS

IR Wireless

IR Frequency : 36 to 38 kHz IR

Formats: Crestron format, RC5

Range: Up to 50 ft line of sight (typical), dependent upon angle, obstructions, IR interference, and IR remote signal strength

Connectors

NET: 4-pin 3.5mm detachable terminal block;

Cresnet slave port, connects to Cresnet control network

LED Indicators

(1 red) Indicates IR signal reception, Cresnet network communication, and setup/update functions

Controls

(1) Recessed miniature pushbutton for setup

Power Requirements

Cresnet Power Usage : 1 Watt (0.042 Amps @ 24 Volts DC)

Environmental

Temperature: 41° to 104°F (5° to 40°C)

Humidity: 10% to 90% RH (non-condensing)

Enclosure

Injection-molded plastic with smoked plastic face, 1-gang mountable in an electrical box using Decora® faceplate (not included)

Dimensions (Without Faceplate)

Height: 4.13 in (10.48 cm)

Width: 1.75 in (4.45 cm)

Depth: 1.37 in (3.45 cm)

Weight

2.4 oz (68.0 g)



C2N-IRGW-1G IR Gateway, Wall Mount

Front View

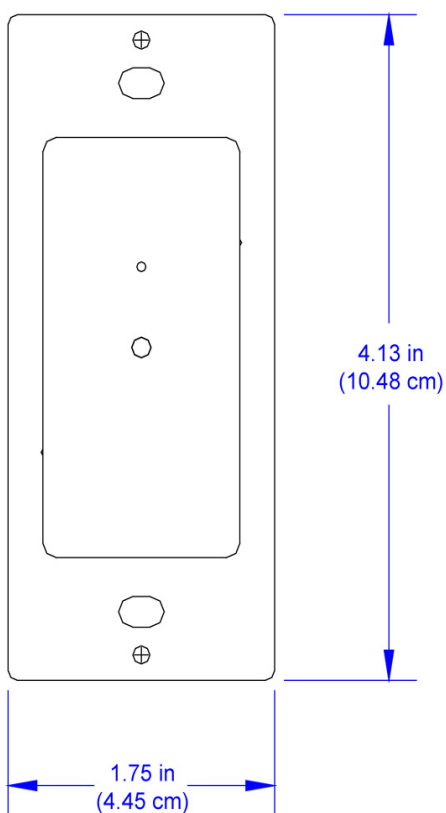

Side View

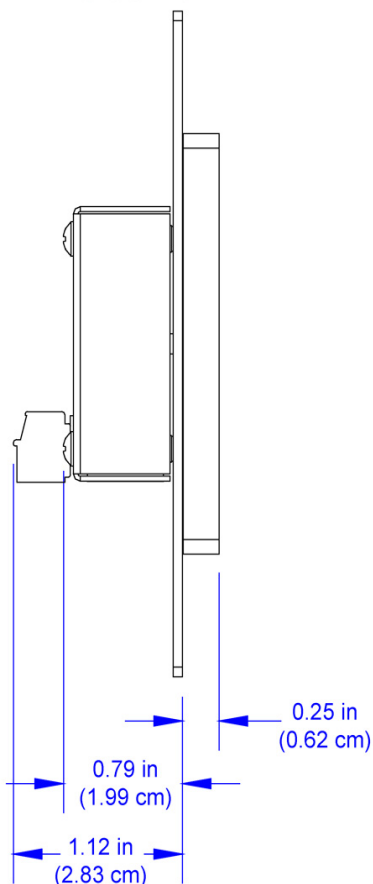

Rear View

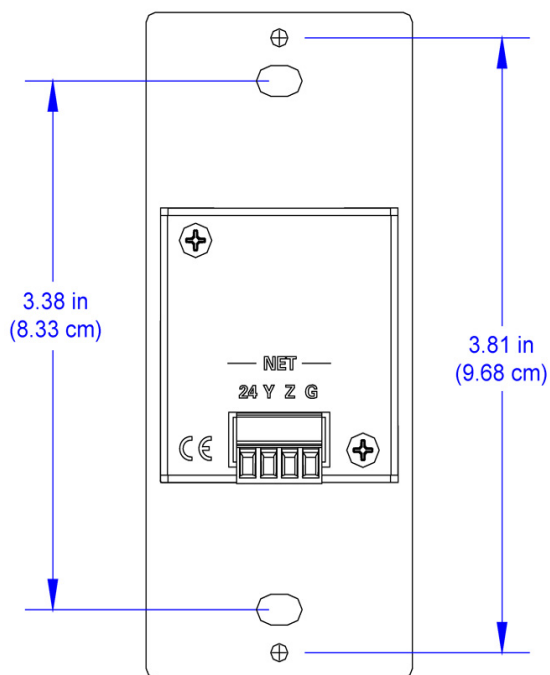

Top View

